

**ISOMETRIC VIEW
(FRONT)**

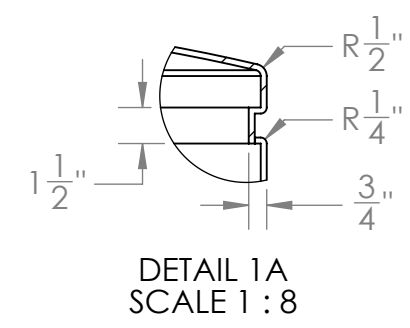

1°
LID ANGLE

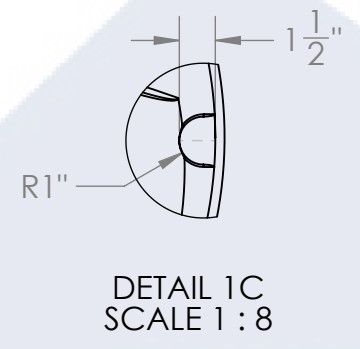
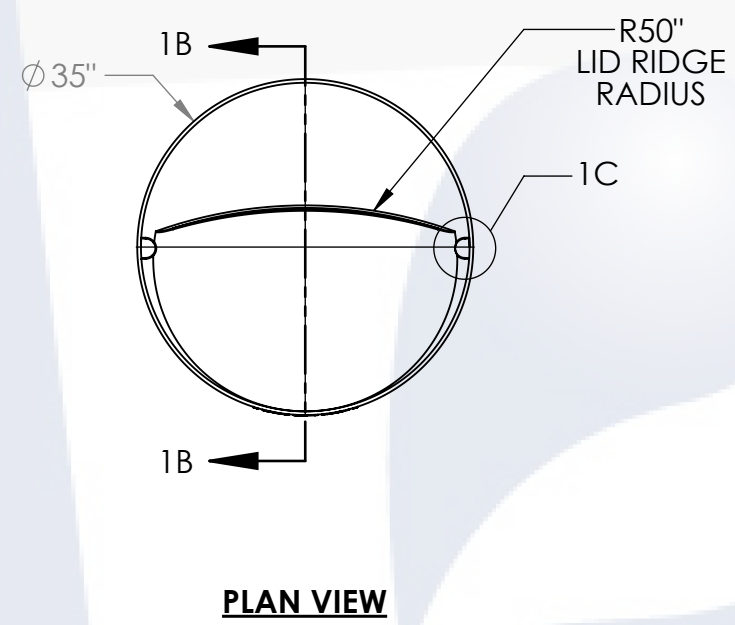
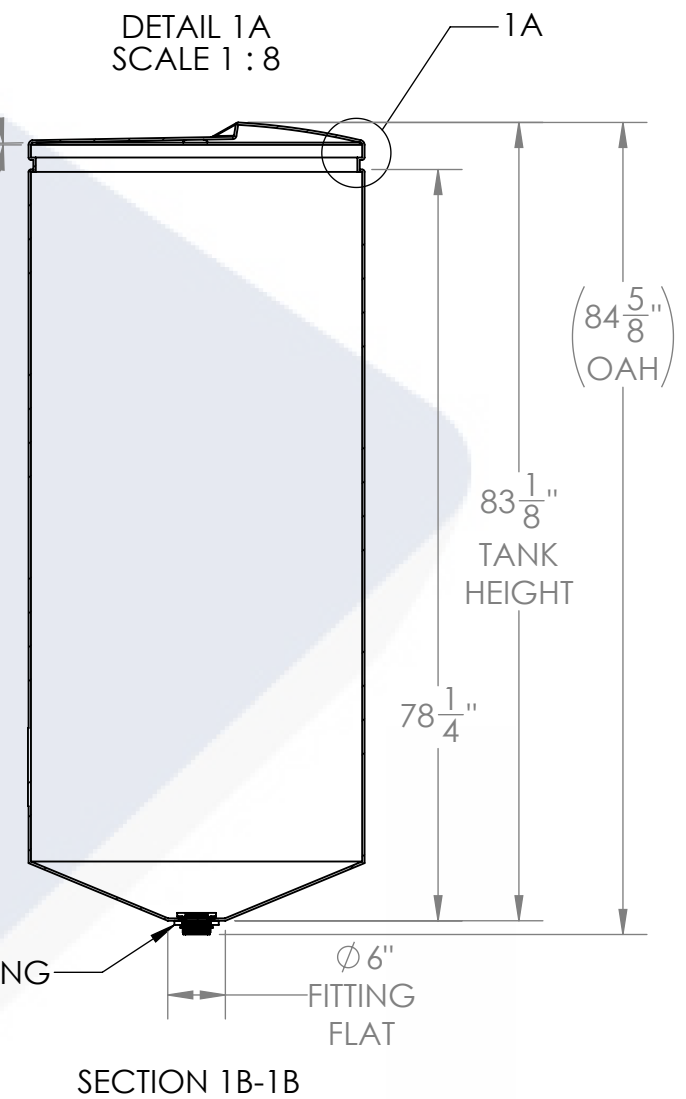

SECTION 1B-1B

- NOTES:**
- CAPACITY: 300 GAL. NOMINAL
 - TANK MATERIAL: MDPE
 - SERVICE PRESSURE: ATMOSPHERIC
 - NSF/ANSI STANDARD 61 CERTIFIED

PROPRIETARY AND CONFIDENTIAL
THE INFORMATION CONTAINED IN THIS DRAWING IS THE SOLE PROPERTY OF PEABODY ENGINEERING. ANY REPRODUCTION IN PART OR AS A WHOLE WITHOUT THE WRITTEN PERMISSION OF PEABODY ENGINEERING IS PROHIBITED.

UNLESS OTHERWISE SPECIFIED:
DIMENSIONS ARE IN INCHES
TOLERANCES: ±1/4"
ANGULAR: ±.5°
ONE PLACE DECIMAL: ±.125
TWO PLACE DECIMAL: ±.063
THREE PLACE DECIMAL: ±.016

TANK MATERIAL: -
INNER TANK S/N:
OUTER TANK S/N:
CUSTOMER PO#

DO NOT SCALE DRAWING

	NAME	DATE
DRAWN	SMF	03/01/23
CHECKED		
ENG APPR.		
MFG APPR.		
Q.A.		

			PROJECT:	PROCHEM® TANKS	
			CUSTOMER:	PEABODY STANDARD	
			SITE/LOCATION:	-	
			SALES ORDER:	-	
SIZE	DESC.		REV.		
B	300GAL CONE BOTTOM TANK		B		
SCALE: 1:20			SHEET 1 OF 1		